

SOIL SAMPLING TOOLS

4

Mobile designs and manufactures the most widely used sampling tools and accessories on the market today. Used in conjunction with our complete line of hollow stem augers, they meet both the industry's geotechnical and environmental sampling demands.

Sampling tools to recover representative samples are available in two distinct types: those to recover disturbed samples and those to recover relatively undisturbed samples.

The first type recovers samples that contain all constituents in their proper portions but not necessarily in their natural or insitu form and are generally used for environmental applications. Examples are the ADO or LYNAC Standard Penetration Samplers. The second type, such as the thin wall or "Shelby" Tube Sampler, are generally used for geo-technical and environmental applications to recover high quality samples suitable for detailed laboratory analysis.

Environmental exploration requires sampler liners that are chemically compatible with the subject formation for custodial care of potentially dangerous samples. Conditions may also require frequent health examinations, possible use of protective clothing with respirators, extensive training and special permits.

To help meet this challenge, a series of new techniques and tools have been developed by MOBILE DRILL® such as the MOSS (Mobile Open Spindle Sampling System), which includes both a basic and an overshot series for 3-1/4" (83mm) through 6-5/8" (168mm) I.D. hollow stem augers. This new equipment provides at least a two-fold increase in productivity without a reduction in quality. This equipment also facilitates the rapid and accurate completion of the environmental inventories mandated by federal, state and local regulations.

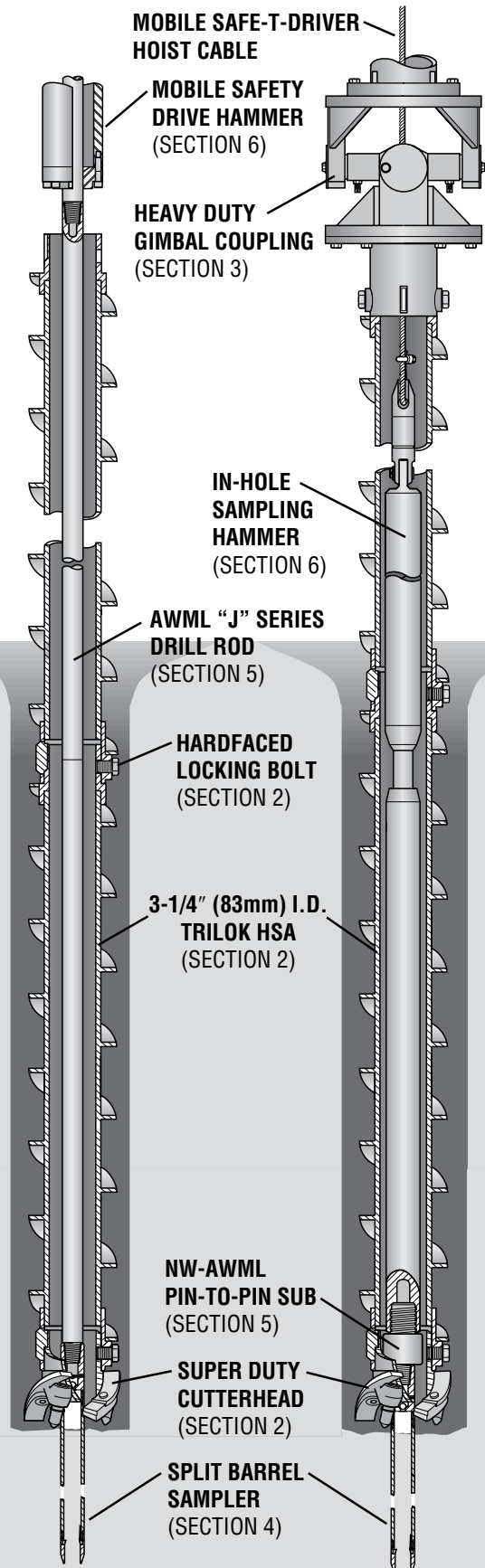

Key: * Designates weights less than 1 lb (.5kg)

†Consult Factory

4-1

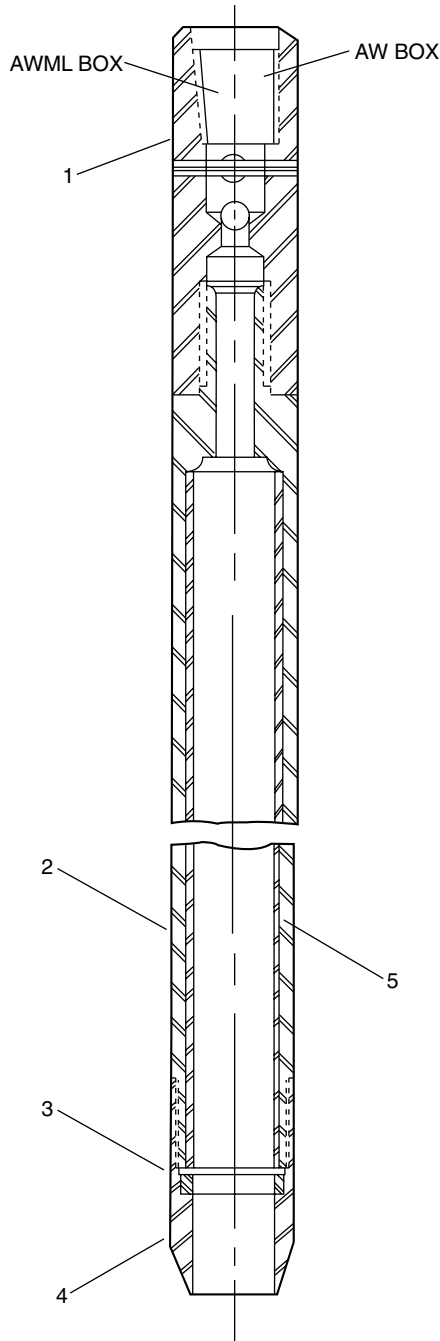

MOBILE'S LYNAC® SPLIT BARREL SAMPLER (FAST THREAD VERSION)

Mobile's LYNAC® Sampler is an improved version of the industry standard split barrel sampler. It includes a shoe, barrel and head with "fast threads" to speed assembly and disassembly. Optional **MOBILOK™**, tapered threads (AWML) expedite attaching the sampler to driving tools. Normally driven by a 140 lb. Safety Hammer, an In-Hole Sampling Hammer or **Mobile's SPT Automatic Hammer**. The sampler barrel has a stepped-joint design to facilitate reassembly of the barrel and a heat-treated shoe to better withstand severe driving conditions. In addition, a ball check valve prevents wash-out during removal from the hole and the shoe design accommodates a Flap Valve or Spring Retainer. Recommended for all Standard Penetration Test procedures. Furnished with a spacer, order sample retainers separately. **Sizes are identified by sampler O.D.**

SAMPLER ASSEMBLY: TERZAGHI (BLUNT) SHOE

Description	Lb/Kg	Part No.
1'6" (457mm), AW	14 (6.4)	67039-12
2'0" (610mm), AW	17 (7.7)	67039-17
1'6" (457mm), AWML	14 (6.4)	67039-02
2'0" (610mm), AWML	17 (7.7)	67039-07

SAMPLER ASSEMBLY: ASTM (SHARP) SHOE

Description	Lb/Kg	Part No.
1'6" (457mm), AW	14 (6.4)	67039-11
2'0" (610mm), AW	17 (7.7)	67039-16
1'6" (457mm), AWML	14 (6.4)	67039-01
2'0" (610mm), AWML	17 (7.7)	67039-06

COMPONENT PARTS

Ref	Description	Lb/Kg	Part No.
1	Head Assembly, AW Box	4 (1.8)	67024-06
1	Head Assembly, AWML Box	4 (1.8)	67024-05
2	Split Barrel: 1'6" (457mm), Set of 2	9 (4.1)	67025-16
2	Split Barrel: 2'0" (610mm), Set of 2	10 (4.5)	67025-17
3	Spacer (for use w/o retainer or flap valve)	*	190006-01
3a	Basket Retainer, Heavy Duty, Steel	*	002417
3b	Basket Retainer, Light Duty, Plastic	*	190176
3c	Spring Retainer, Light Duty, Steel (006746 Req'd)	*	005420
3d	Adapter Ring (for use with 005420)	*	006746
3e	Flap Valve, Heavy Duty, Steel	*	002421
4	Blunt Shoe	1 (.5)	190071-05
4	Sharp Shoe	1 (.5)	190071-06
5	Plastic Liner, 1'6" (457mm)	*	190138-04
5	Plastic Liner, 2'0" (610mm)	*	190138-05

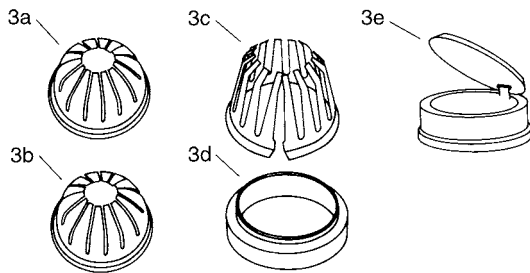

SAMPLE RETAINERS

SPLIT BARREL SAMPLERS

All-purpose sampler used for visual classification, contamination content and moisture determination. The split barrel permits removal of sample as it is taken from the ground. Generally driven by a 140 lb (63.5kg) safety hammer, an in-hole sampling hammer or **Mobile's SPT Automatic Hammer**, falling 2'6" (762mm). The number of blows required to penetrate each half foot is often recorded as the relative density of material. In non-cohesive soils, the sampler is used with a flap valve, light duty or heavy duty basket trap. 2' (51mm) samplers are available with both standard and **MOBILOK™** (AWML) thread design. **Sizes are identified by sampler O.D.** Furnished with spacer, order sample retainers separately. Other sizes than shown are available. Please consult factory.

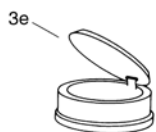
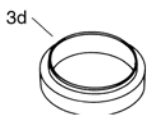
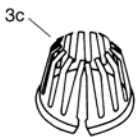
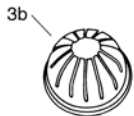
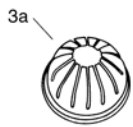
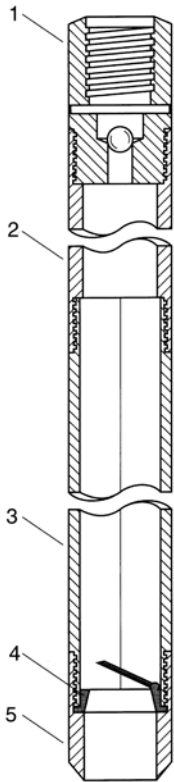

4 THREADS PER INCH SPLIT BARREL SAMPLER

SAMPLER OD	SAMPLER ID	SHOE ID	LENGTH BARREL	ROD CONN.	SHOE TYPE		WEIGHT	
					TERZAGHI (BLUNT)	ASTM (SHARP)	lb	kg
2" (50.8mm)	1.5" (38.1mm)	1.375" (34.9mm)	18" (457.2mm)	AW	67006-13	67006-14	13.6	6.2
				AWML	67006-15	67006-16	13.6	6.2
			24" (609.6mm)	AW	67006-17	67006-18	16.0	7.3
				AWML	67006-19	67006-20	16.0	7.3
2.5" (63.5mm)	2" (50.8mm)	1.875" (47.6mm)	18" (457.2mm)	AW	67007-01	67007-02	18.9	8.6
				AWML	67007-05	67007-06	18.9	8.6
			24" (609.6mm)	AW	67007-03	67007-04	22.4	10.2
				AWML	67007-07	67007-08	22.4	10.2
3" (76.2mm)	2.5" (63.5mm)	2.375" (60.3mm)	18" (457.2mm)	NW	67008-13	67008-14	26.3	11.9
				NW	67008-15	67008-16	28.0	12.7
			24" (609.6mm)	NWML	67008-17	67008-18	26.3	11.9
				NWML	67008-19	67008-20	28.0	12.7

8 THREADS PER INCH SPLIT BARREL SAMPLER

SAMPLER OD	SAMPLER ID	SHOE ID	LENGTH BARREL	ROD CONN.	SHOE TYPE		WEIGHT	
					TERZAGHI (BLUNT)	ASTM (SHARP)	lb	kg
2" (50.8mm)	1.5" (38.1mm)	1.375" (34.9mm)	18" (457.2mm)	AW	67006-10	67006-09	13.6	6.2
				AWML	67006-04	67006-03	13.6	6.2
			24" (609.6mm)	AW	67006-12	67006-11	16.0	7.3
				AWML	67006-06	67006-05	16.0	7.3
2.5" (63.5mm)	2" (50.8mm)	1.875" (47.6mm)	18" (457.2mm)	AW	007104	006434	18.9	8.6
				AWML	67007-09	67007-10	18.9	8.6
			24" (609.6mm)	AW	007105	007100	22.4	10.2
				AWML	67007-11	67007-12	22.4	10.2
3" (76.2mm)	2.5" (63.5mm)	2.375" (60.3mm)	18" (457.2mm)	NW	007109	006437	26.3	11.9
				NW	007111	007110	28.0	12.7
			24" (609.6mm)	NWML	67008-04	67008-03	26.3	11.9
				NWML	67008-06	67008-05	28.0	12.7

Continued on next page

Key: * Designates weights less than 1 lb (.5kg)

† Consult Factory

SOIL SAMPLING TOOLS

4

4 THREADS PER INCH SPLIT BARREL SAMPLER - COMPONENT PARTS

REF. NO.	DESCRIPTION	2" OD (50.8MM)			2.5" OD (63.5MM)			3.0" OD (76.2MM)		
		PART NO.	WEIGHT lbs	WEIGHT kg	PART NO.	WEIGHT lbs	WEIGHT kg	PART NO.	WEIGHT lbs	WEIGHT kg
1	Head Assy, w/ AW Box Connection	67021-14	2.3	1.0	67021-15	4.0	1.8	67021-22	†	†
1	Head Assy, w/ AWML Box Connection	67021-16	2.3	1.0	67021-21	†	†	67021-23	†	†
1	Head Assy, w/ NW Box Connection	N/A	—	—	N/A	—	—	67021-17	—	—
1	Head Assy, w/ NWML Box Connection	N/A	—	—	N/A	—	—	67021-19	—	—
2	Waste Barrel	006069	†	†	006070	†	†	006071	†	†
3	18" (457.2mm) Split Barrel	67022-17	6.6	3.0	67022-18	8.3	3.8	67022-19	11.0	5.0
3	24" (609.6mm) Split Barrel	67022-21	8.8	4.0	67022-22	11.0	5.0	67022-23	13.0	5.9
4	Spacer	190006-01	*	*	190006-02	*	*	190006-03	*	*
5	Shoe, Terzaghi (blunt)	190071-40	1.0	.5	190071-41	1.6	.7	190071-42	2.0	.9
5	Shoe, ASTM (sharp)	190071-44	1.0	.5	190071-45	1.6	.7	190071-46	2.0	.9
	Optional Accessories									
	18" (457.2mm) Plastic Liner	190077-02	*	*	†	†	†	†	†	†
	24" (609.6mm) Plastic Liner	190077-03	*	*	†	†	†	†	†	†
	Spring Retainer (light duty steel)	005420	*	*	†	†	†	†	†	†
	Adaptor Ring (for light duty steel)	006746	*	*	†	†	†	†	†	†
	Basket Retainer (heavy duty)	190033	*	*	002418	*	*	002419	*	*
	Basket Retainer (plastic)	190165	*	*	190165-05	*	*	190177	*	*
	Flap Valve	002421	*	*	002422	*	*	002423	*	*

8 THREADS PER INCH SPLIT BARREL SAMPLER - COMPONENT PARTS

REF. NO.	DESCRIPTION	2" OD (50.8MM)			2.5" OD (63.5MM)			3.0" OD (76.2MM)		
		PART NO.	WEIGHT lbs	WEIGHT kg	PART NO.	WEIGHT lbs	WEIGHT kg	PART NO.	WEIGHT lbs	WEIGHT kg
1	Head Assy, w/ AW Box Connection	67021-02	2.3	1.0	006340	4.0	1.8	67021-25	†	†
1	Head Assy, w/ AWML Box Connection	67021-01	2.3	1.0	67021-24	†	†	67021-26	†	†
1	Head Assy, w/ NW Box Connection	N/A	—	—	N/A	—	—	006341	—	—
1	Head Assy, w/ NWML Box Connection	N/A	—	—	N/A	—	—	67021-03	—	—
2	Waste Barrel	006069	†	†	006070	†	†	006071	†	†
3	18" (457.2mm) Split Barrel	67022-02	6.6	3.0	006078	8.3	3.8	67021-05	11.0	5.0
3	24" (609.6mm) Split Barrel	67022-03	8.8	4.0	006082	11.0	5.0	001113	13.0	5.9
4	Spacer	190006-01	*	*	190006-02	*	*	190006-03	*	*
5	Shoe, Terzaghi (blunt)	190071-01	1.0	.5	007102	1.6	.7	007112	2.0	.9
5	Shoe, ASTM (sharp)	190071-02	1.0	.5	002414	1.6	.7	002415	2.0	.9
	Optional Accessories									
	18" (457.2mm) Plastic Liner	190077-02	*	*	†	†	†	†	†	†
	24" (609.6mm) Plastic Liner	190077-03	*	*	†	†	†	†	†	†
	Spring Retainer (light duty steel)	005420	*	*	†	†	†	†	†	†
	Adaptor Ring (for light duty steel)	006746	*	*	†	†	†	†	†	†
	Basket Retainer (heavy duty)	190033	*	*	002418	*	*	002419	*	*
	Basket Retainer (plastic)	190176	*	*	190165-05	*	*	190177	*	*
	Flap Valve	002421	*	*	002422	*	*	002423	*	*

4-4

Key: * Designates weights less than 1 lb (.5kg)

† Consult Factory

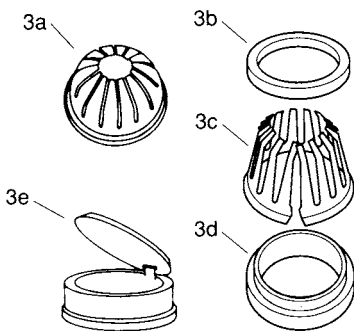
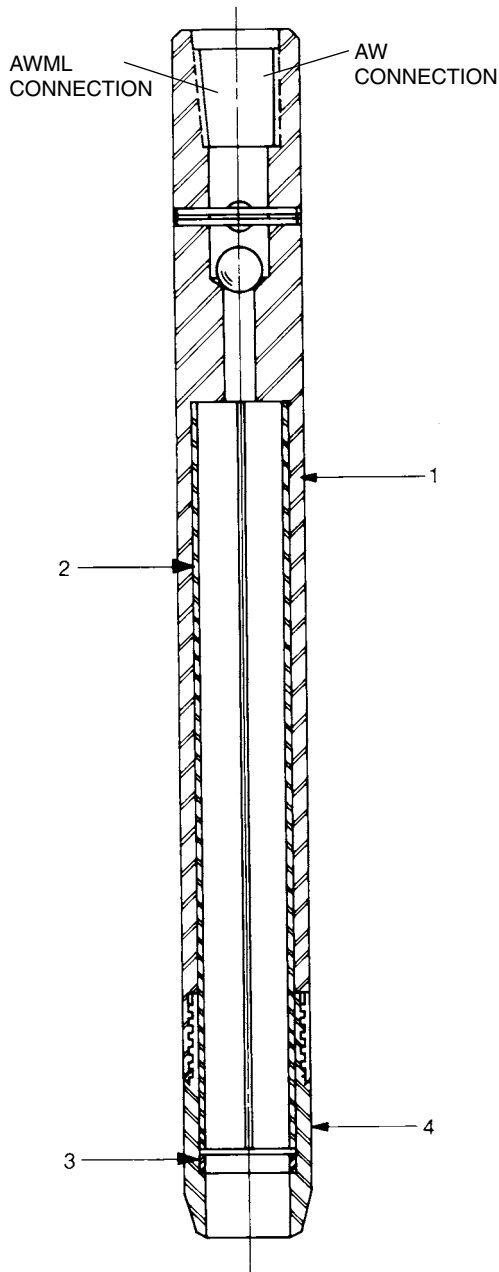

Sample Retainers

ADO STANDARD PENETRATION SAMPLER

Used for the same purpose as the Split Barrel Sampler. Recovers samples for visual inspection in the field and for general classification testing in the laboratory. Specifically designed by Mobile to provide the maximum strength possible under ASTM-1566. The tool consists of two 2'0" (610mm) long split steel halves enclosed within a solid outer tube which is welded to the head section. The sample and split liners are removed by unscrewing the shoe, a process which does not require disconnection of the sampler from the drill rod. Can be furnished with Terzaghi or ASTM type shoe. For use in non-cohesive soils, basket retainers and flap valve are available as separate items. Furnished with spacer, order sample retainer separately. **Sizes are identified by sampler O.D.** Includes ball and roll pin.

Sampler O.D.	Liner I.D.
2" (51mm)	1-3/8" (35mm)
3-1/8" (79mm)	2-1/2" (64mm)

SAMPLER ASSEMBLY: TERZAGHI (BLUNT) SHOE

Description	Lb/Kg	Part No.
2" (51mm) x 2'0" (610mm), AW Box	15 (6.8)	005416
2" (51mm) x 2'0" (610mm), AWML Box	15 (6.8)	67000-01
3-1/8" (79mm) x 2'0" (610mm), NW Box	30 (13.6)	006356
3-1/8" (79mm) x 2'0" (610mm), NWML Box	30 (13.6)	67001-01

SAMPLER ASSEMBLY: ASTM (SHARP) SHOE

Description	Lb/Kg	Part No.
2" (51mm) x 2'0" (610mm), AW Box	15 (6.8)	67000-03
2" (51mm) x 2'0" (610mm), AWML Box	15 (6.8)	67000-02
3-1/8" (79mm) x 2'0" (610mm), NW Box	30 (13.6)	67001-03
3-1/8" (79mm) x 2'0" (610mm), NWML Box	30 (13.6)	67001-02

COMPONENT PARTS: 2" (51MM) O.D.

Ref	Description	Lb/Kg	Part No.
1	Tube, Solid: AW Rod Box	15 (6.8)	005422
1	Tube, Solid: AWML Rod Box	15 (6.8)	150217
2	Liner, Split: Steel, (Set of 2)	4 (1.8)	005421
3	Spacer: (For Use w/o Retainer or Flap Valve).. *		005421
3a	Retainer, Basket: Heavy Duty, Steel	*	003843
3b	Collar, Retainer (For Use w/005420)	*	006067
3c	Retainer, Spring: Lt. Duty, Steel (006067 & 006068 Req'd)	*	005420
3d	Ring, Retainer (For Use w/005420)	*	006068
3e	Valve, Flap Heavy Duty, Steel	*	003890
4	Shoe, Blunt	1 (.5)	005419
4	Shoe, Sharp	1 (.5)	003940

COMPONENT PARTS: 3-1/8" (79MM) O.D.

Ref	Description	Lb/Kg	Part No.
1	Tube, Solid: NW Rod Box	20 (9.1)	006358
1	Tube, Solid: NWML Rod Box	20 (9.1)	150342
2	Liner, Split: Steel, (Set)	4 (1.8)	006361
3	Spacer: (For Use w/o Retainer or Flap Valve).. *		006369
3a	Retainer, Basket: Heavy Duty, Steel	*	006367
3e	Valve, Flap Heavy Duty, Steel	*	006368
4	Shoe, Blunt	2 (.9)	005419
4	Shoe, Sharp	2 (.9)	006359

Key: * Designates weights less than 1 lb (.5kg)

† Consult Factory

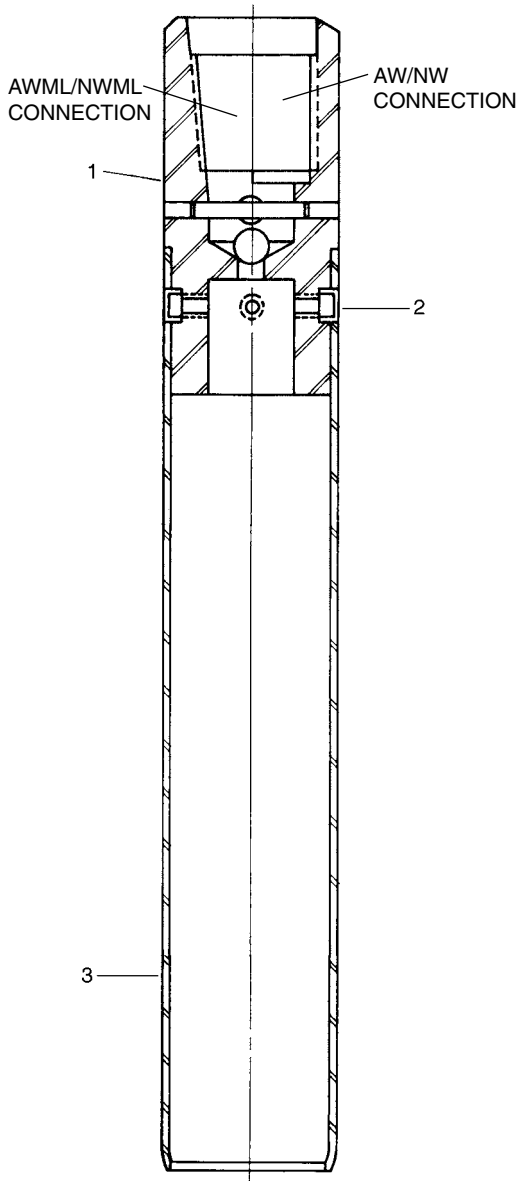

"SHELBY" TUBE SAMPLER

This sampler is the simplest and probably most widely used of the "insitu" quality samplers. It consists of a head section which contains a check valve and drill rod box connector and a thin wall sample tube. The tube is loosely attached to the head by means of four socket head capscrews which are turned "in", or clockwise, to remove the tube. During the sampling operation, the tube moves slightly upward to bear against a shoulder which is machined into the head section thus assuring absolutely uniform force application to the tube. "Shelby" samplers are furnished complete with ball valve for positive vacuum control. Sampler should be forced down under steady pressure. Standard tube length is 2'6" (762 mm). Heads are available with both standard and **MOBILOK™** (AWML & NWML) thread designs. **Sizes are identified by sampler O.D.**

SAMPLER ASSEMBLY

Description	Lb/Kg	Part No.
2" (51mm) x 2'6" (762mm), AW Box.....	9 (4.1)	67010-07
2" (51mm) x 3'0" (914mm), AW Box.....	10 (4.5)	67010-08
2" (51mm) x 2'6" (762mm), AWML Box.....	9 (4.1)	67010-01
2" (51mm) x 3'0" (914mm), AWML Box.....	10 (4.5)	67010-02
3" (76mm) x 2'6" (762mm), AW Box	11 (5)	67013-07
3" (76mm) x 3'0" (914mm), AW Box.....	13 (5.9)	67013-08
3" (76mm) x 2'6" (762mm), AWML Box	11 (5)	67013-01
3" (76mm) x 3'0" (914mm), AWML Box.....	13 (5.9)	67013-02
3" (76mm) x 2'6" (762mm), NW Box	17 (7.7)	67013-19
3" (76mm) x 3'0" (914mm), NW Box	18 (8.2)	67013-20
3" (76mm) x 2'6" (762mm), NWML Box.....	17 (7.7)	67013-13
3" (76mm) x 3'0" (914mm), NWML Box	18 (8.2)	67013-14

COMPONENT PARTS: 2" (51MM) O.D.

Ref	Description	Lb/Kg	Part No.
1	Head, AW Box (with Ball & Roll Pin).....	6 (2.7)	67026-06
1	Head: AWML Box (with Ball & Roll Pin).....	6 (2.7)	67026-05
2	Screw (4 required).....	*	006404
3	Tube: 2'6" (762mm), Steel	3 (1.4)	190044-01
3	Tube: 3'0" (914mm), Steel.....	4 (1.8)	190044-02
4	Cap, Plastic	*	006425

COMPONENT PARTS: 3" (76MM) O.D.

Ref	Description	Lb/Kg	Part No.
1	Head, AW Box (with Ball & Roll Pin) (Requires 4 screws).....	9 (4.1)	67026-02
1	Head, AWML Box (with Ball & Roll Pin) (Requires 4 screws).....	9 (4.1)	67026-01
1	Head, NW Box (with Ball & Roll Pin) (Requires 4 screws).....	12 (5.4)	67026-04
1	Head, NWML Box (with Ball & Roll Pin) (Requires 4 screws).....	12 (5.4)	67026-03
2	Screw (4 required).....	*	006405
3	Tube, 2'6" (762mm), Steel+	5 (2.3)	190047-01
3	Tube, 3'0" (914mm), Steel+	6 (2.7)	190047-02
4	Cap, Plastic 3" (76mm)	*	005227

+ Galvanized tubes available.