

Mobile Drill Intl

HELPING YOU BUILD OUR WORLD SINCE 1947

Mechanical Drill

B51



MULTI-PURPOSE

A COMPACT DRILL WITH BIG RIG PERFORMANCE

AUGER • ROTARY • CORING

B51 Drilling Features

- 9,876 ft-lb Torque
- 669 rpm
- Open Spindle: 2 inch ID
- Under 14,000 lbs Track Mounted
- The New Standard for Geotechnical Drilling applications.

B51

Compact
Mechanical
Drill



PERFORMANCE SPECIFICATIONS

Feed System

Pulldown Force: 15,708 lbs [7,125 kg]

Retract Force: 24,544 lbs [11,133 kg]

Feed Speed, Down: 0-53 ft/min [0-16 m/min]

Feed Speed, Retract: 0-34 ft/min [0-10 m/min]

Feed stroke: 6 ft [1.83 m]

Power Unit

Deck Engines: John Deere, Tier 4, 74 hp or Deutz Diesel

Drill Head Rotary

Total enclosed "dry box" with tapered roller bearings.

1-3/4" Steel Kelly Drive Bar

Open Spindle Bore: 2 in [51 mm]

Maximum Torque and rpm (Engine Specific):

John Deere

9,876 ft-lb [13,390 Nm] @ 20 rpm, Maximum 618 rpm

Deutz

7,110 ft-lb [9,640 Nm] @ 20 rpm, Maximum 669 rpm

Hoists

Main-Single Line Capacity: 6,000 lbs [2,722 kg]

Main-Single Line Capacity: 4,500 lbs [2,041 kg]

Safe-T-Driver/Wireline: 900 lbs [408 kg]

Wireline Hoists - A Wide Variety Available

Line Capacities from 700 ft [213 m] to 7,500 ft [2,286 m]

Estimated Operating Capacities

Hollow Stem Augers, 4-1/4 in [108 mm] ID: 130 ft [40 m]

Continuous Flight Auger, 6 in [152 mm] OD: 225 ft [67 m]

Rotary Drilling, NWJ/NW: 1,000 ft [305 m]

Diamond Core Drilling, N Wireline: 900 ft [275 m]

Note: Above drilling capacities may vary according to sub-surface conditions, hoist capacity and rotary head option.

Optional Equipment

- Mast: 20 ft [6.1 m] or 25 ft [7.6 m]
- In-Out/Side-to-Side Slide Base
- SPT Automatic Hammer, ASTM D-1586, 140 lb [64 kg], 170 lb [77 kg], 300 lb [136 kg], 340 lb [154 kg]
Slugs Available
- Custom Breakout Table Designs
- Make/Break Double Rod Clamp System
- Hydraulic Breakout Wrench
- Water Pumps - Piston, Centrifugal and Progressive Cavity
- Water/Foam Injection Systems
- Swing-Out Under Body Auger Racks
- Water Tanks
- Driller/Helper Platforms
- Safety Cage Options
- Night Lights

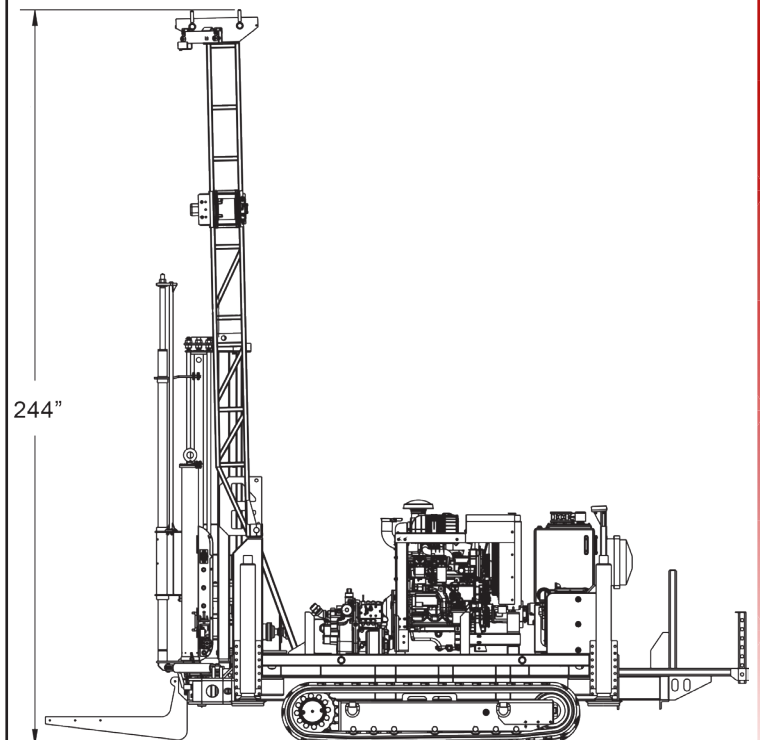
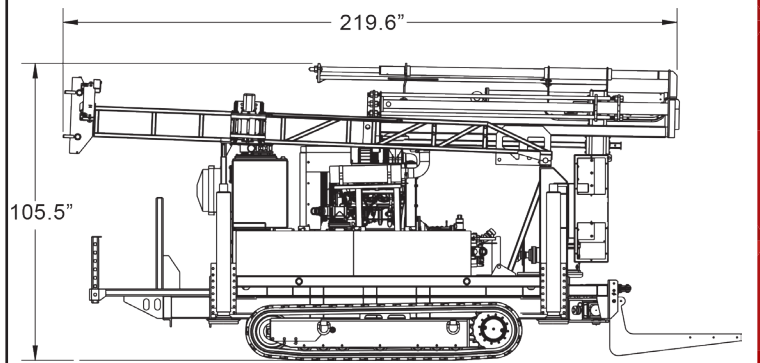
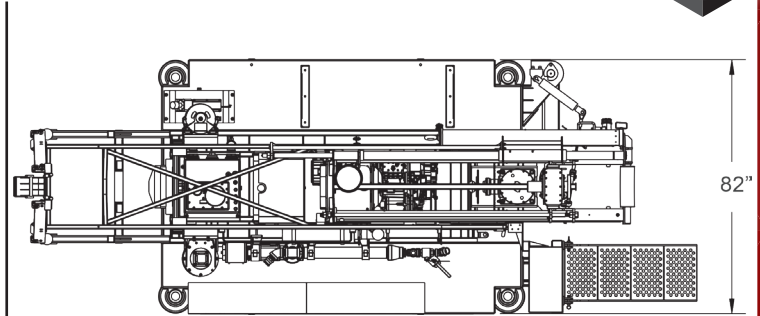

NOTE: Engineering specifications are theoretical, actual performance will be different, specifications are subject to change without notice.

