



Mobile Drill Intl

YOUR DRILL RIG SALES AND SERVICE EXPERTS SINCE 1947

MM The Minuteman

Gasoline/Electric Man-Portable Drill



Pre-Bid Drilling
Concrete Core Drilling
Asphalt Core Drilling
Test Drilling

MM Drilling Benefits

- Economical, Compact, Lightweight, Portable Drill
- Shallow Continuous Flight or Hollow Stem Auger Work
- Standard Dolly-Mount Offers Portability and Positioning Ability
- Gasoline Engine or Electric Motor
- Maximum Rotary Speed of 1,000 rpm (104.7 rad/s)
- 44-in (1.12 m) Feed Stroke
- Maximum Torque of 664 ft-lbs (900 Nm)



The Minuteman

PERFORMANCE SPECIFICATIONS

Minuteman - Gasoline Powered

With a total weight of only 328 lbs (148 kg), the gas powered Minuteman goes just about anywhere

Rotary Drive System

- Rotary Torque: 664 ft-lbs (900 Nm)
- Maximum Rotary Speed: 1,000 rpm (104.7 rad/s)

Dimensions

- Height: 732 in (1.85 m)
- Width: 32 in (812.8 mm)
- Length: 28 in (711.2 mm)
- Weight: 328 lbs (148 kg)
- Feed Stroke (Standard): 44 in (1.12 m)

Estimated Operating Capacities

- Auger, 3-in (76.2 mm): 35-ft (10.67 m)
- Auger, 12-in (304.8 mm): 3-ft (.91 m)
- Concrete/Asphalt Core Drilling: 1-8 in (25.4 to 203.2 mm)

Note: Above drilling capacities may vary according to subsurface conditions.

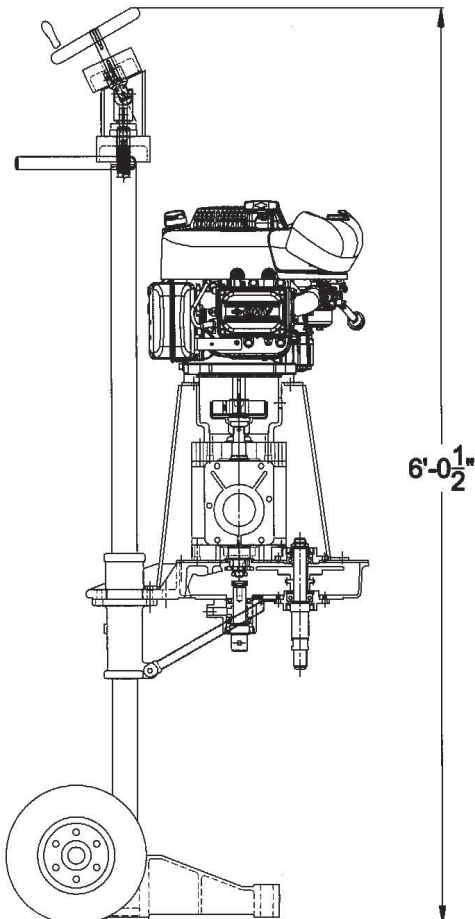

Minuteman - Electric Powered

The electric powered Minuteman has zero emissions and no combustible fluids, making it ideal for indoor or underground applications. It is available in 220V single phase or 208V, 230V, 460V, and 575V triple phase.

Rotary Drive System

- Rotary Torque: 446 ft-lbs (604.7 Nm)
- Maximum Rotary Speed: 1,068 rpm (111.84 rad/s)

Dimensions

- Height: 73-in (1.85 m)
- Width: 32-in (812.8 mm)
- Length: 28-in (711.2 mm)
- Weight: 328 lbs (148 kg)
- Feed Stroke (Standard): 44 in (1.12 m)

Estimated Operating Capacities

- Auger, 3-in (76.2 mm): 35-ft (10.67 m)
- Auger, 12-in (304.8 mm): 3-ft (.91 m)
- Concrete/Asphalt Core Drilling: 1-8 in (25.4 to 203.2 mm)

Note: Above drilling capacities may vary according to subsurface conditions.

